

Inflatable boat GALA Freestyle F300A

Technical drawing

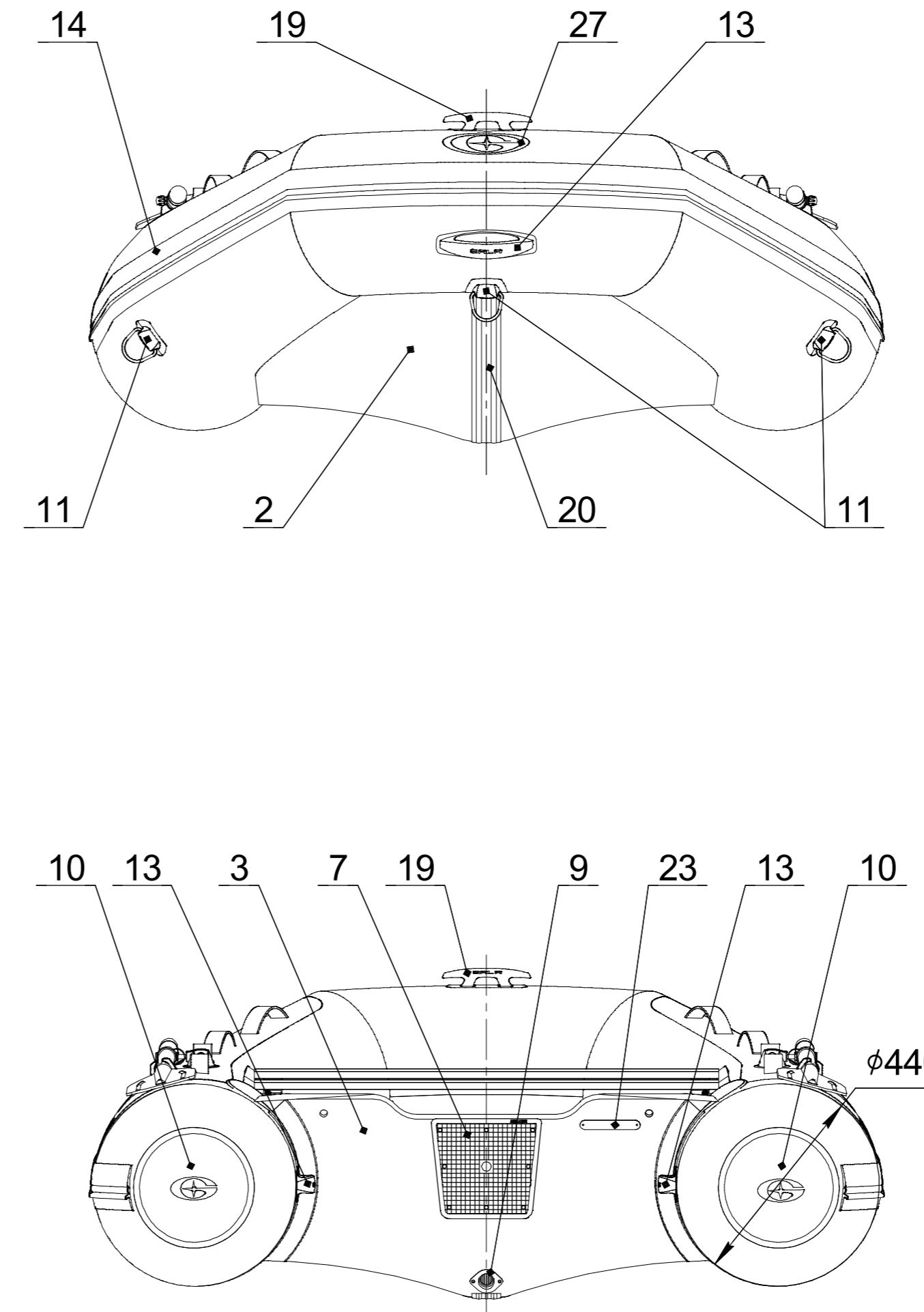
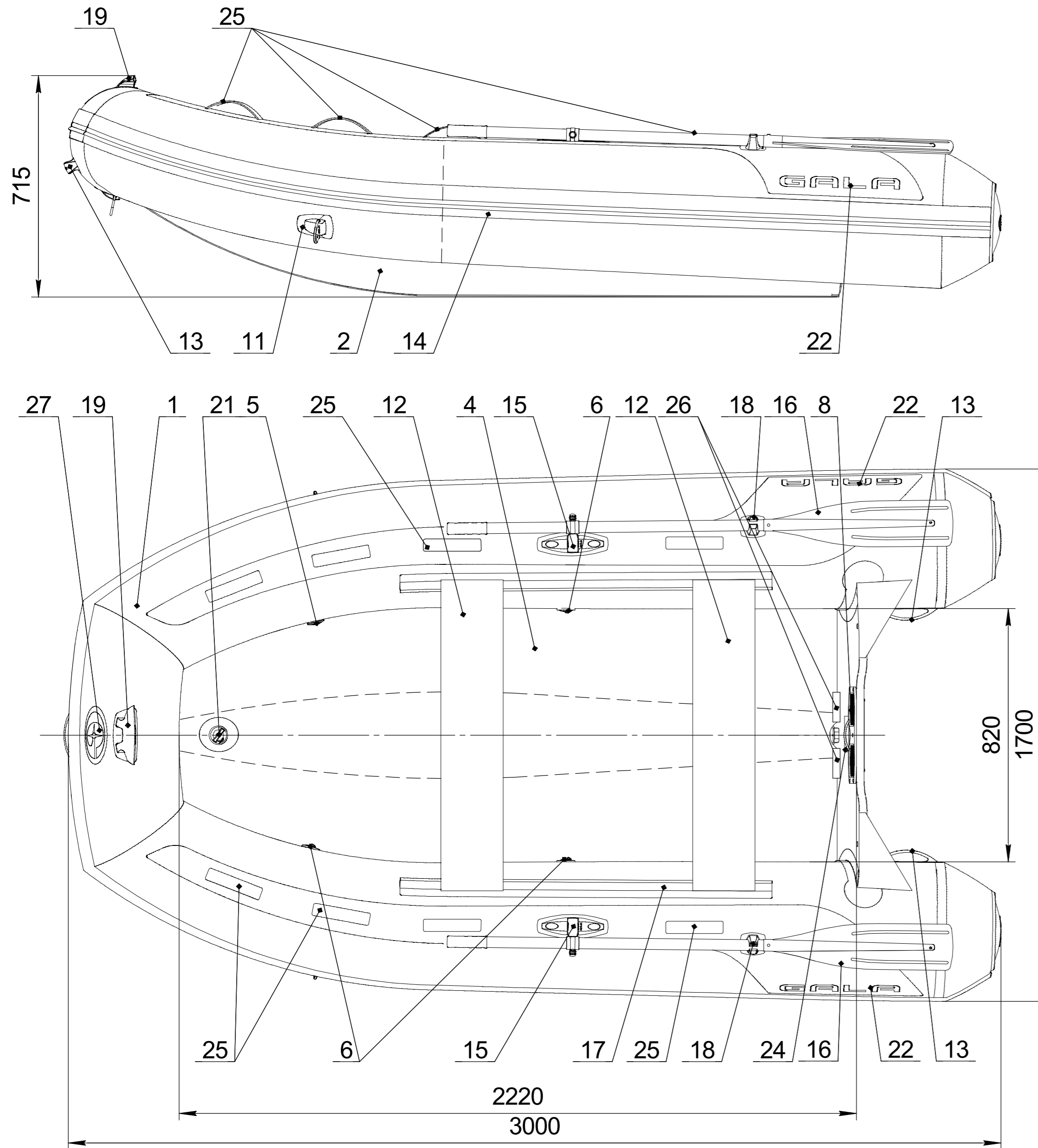

Builder's plate

GALA
INFLATABLE BOATS

Model **F300A** 5 + 1

500 kg 1100 lbs

11 kW 15 HP Type **V**

50 kg 110 lbs Cat. **C**

0.2 bar 2.89 psi International Standard ISO/FDIS-6185

MADE IN UKRAINE
 "CALIBR PROF" LLC
4, Matlakhova Str., Dnipro, UKRAINE

Boat specification

Item	Item No	Description	Q-ty	Note
1		Inflatable tube for F300A	1	
2		V-shape bottom for F300A	1	
3		Integral marine grade ply transom for F300A	1	
4		AirDeck for F300A	1	
5		Over pressure valve	1	
6		Inflation-deflation valve	3	
7		Motor plate external	1	
8		Motor plate internal	1	
9		Expanding drain plug	1	
10		Tube end, PVC	2	
11		Towing eye, PVC	3	
12		Aluminum seat	2	
13		GALA handle, PVC	3	
14		Rubbing strake	1	
15		Oarlock	2	
16		Oar 160 cm with rivert	2	
17		Seat holder	2	
18		Oar holder	2	
19		GALA cleat, PVC	1	
20		Keel protector	1	
21		Inflatable keel with inflation-deflation valve	1	
22		GALA logo	2	
23		CIN plate	1	
24		Builder's plate	1	
25		Safety grab handle	8	
26		Floor stop	2	
27		GALA logo front	1	

NAME	DATE	ITEM No:		
DRAWN				
CHECKED		TITLE:		
ENG APPR.		GALA Freestyle F300A		
MFG APPR.				
Q.A.				
PROPRIETARY AND CONFIDENTIAL THE INFORMATION CONTAINED IN THIS DRAWING IS THE SOLE PROPERTY OF CALIBR PROF LLC		SIZE	DWG. NO.	REV
SCALE: 1:10		WEIGHT:	SHEET 1 OF 1	