

Inflatable boat GALA Sprinter S210

Technical drawing

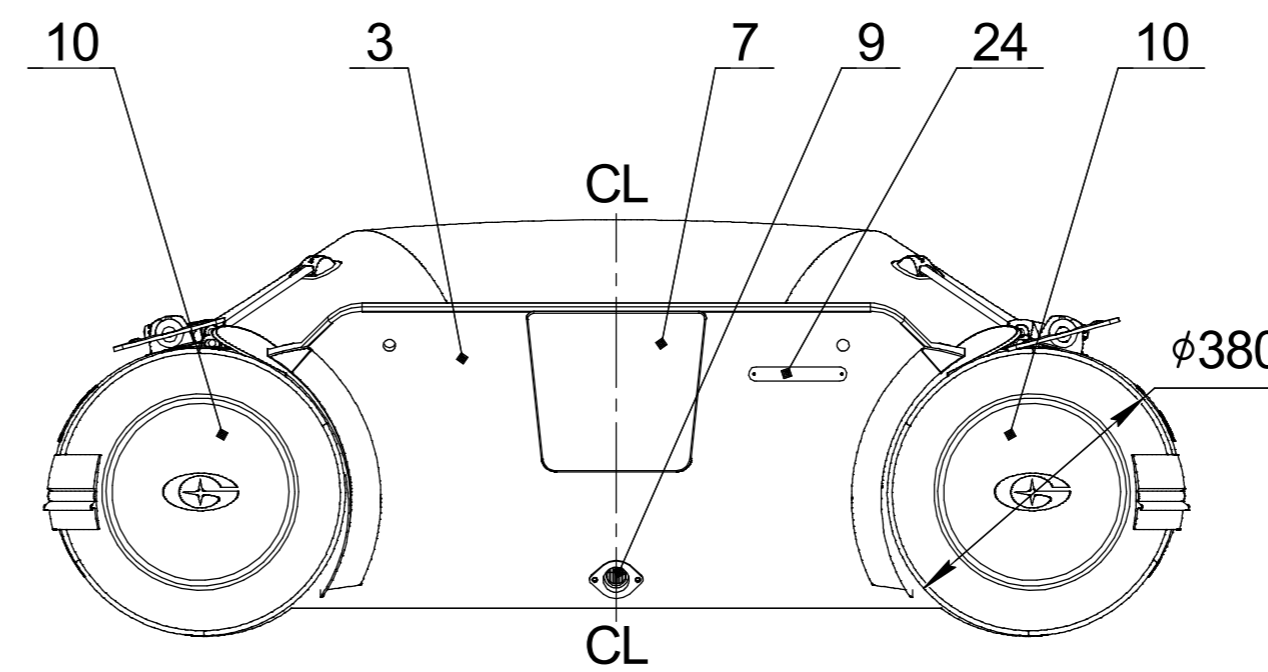
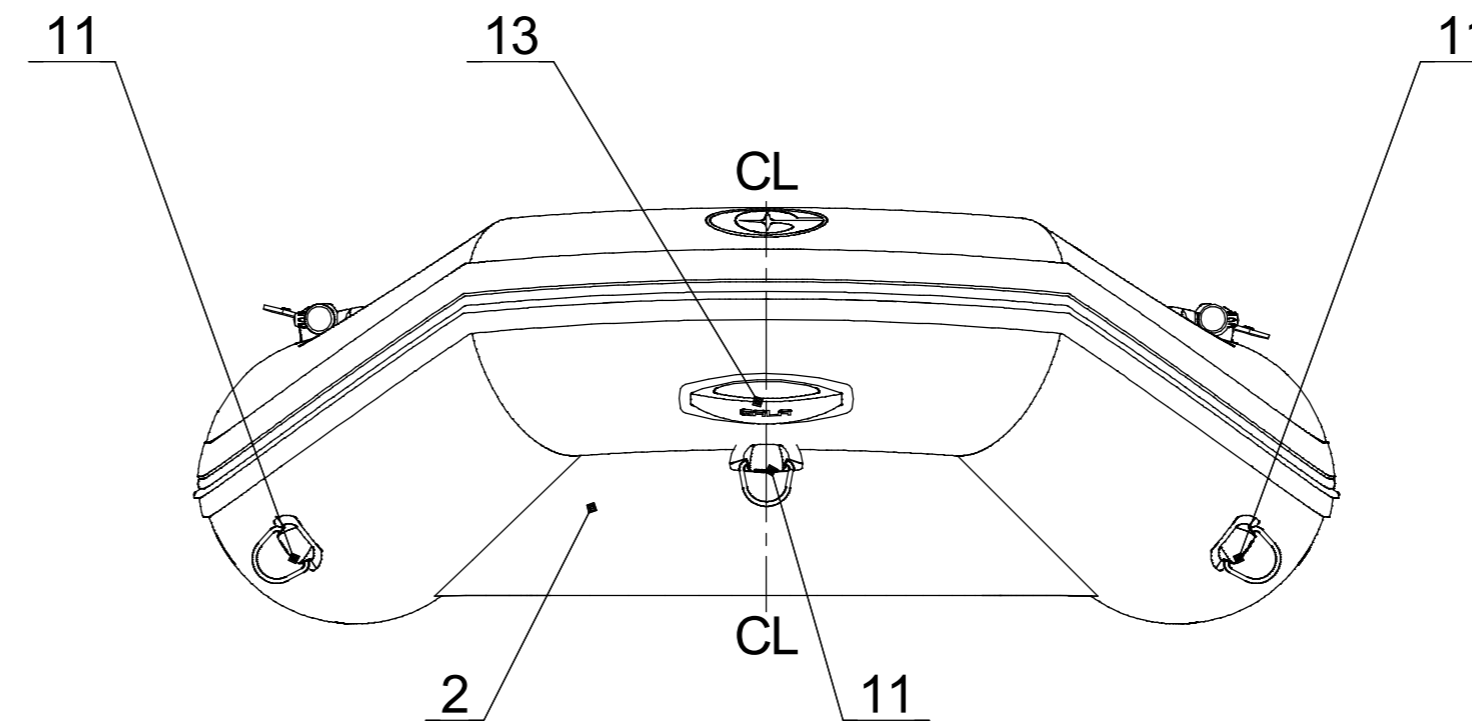
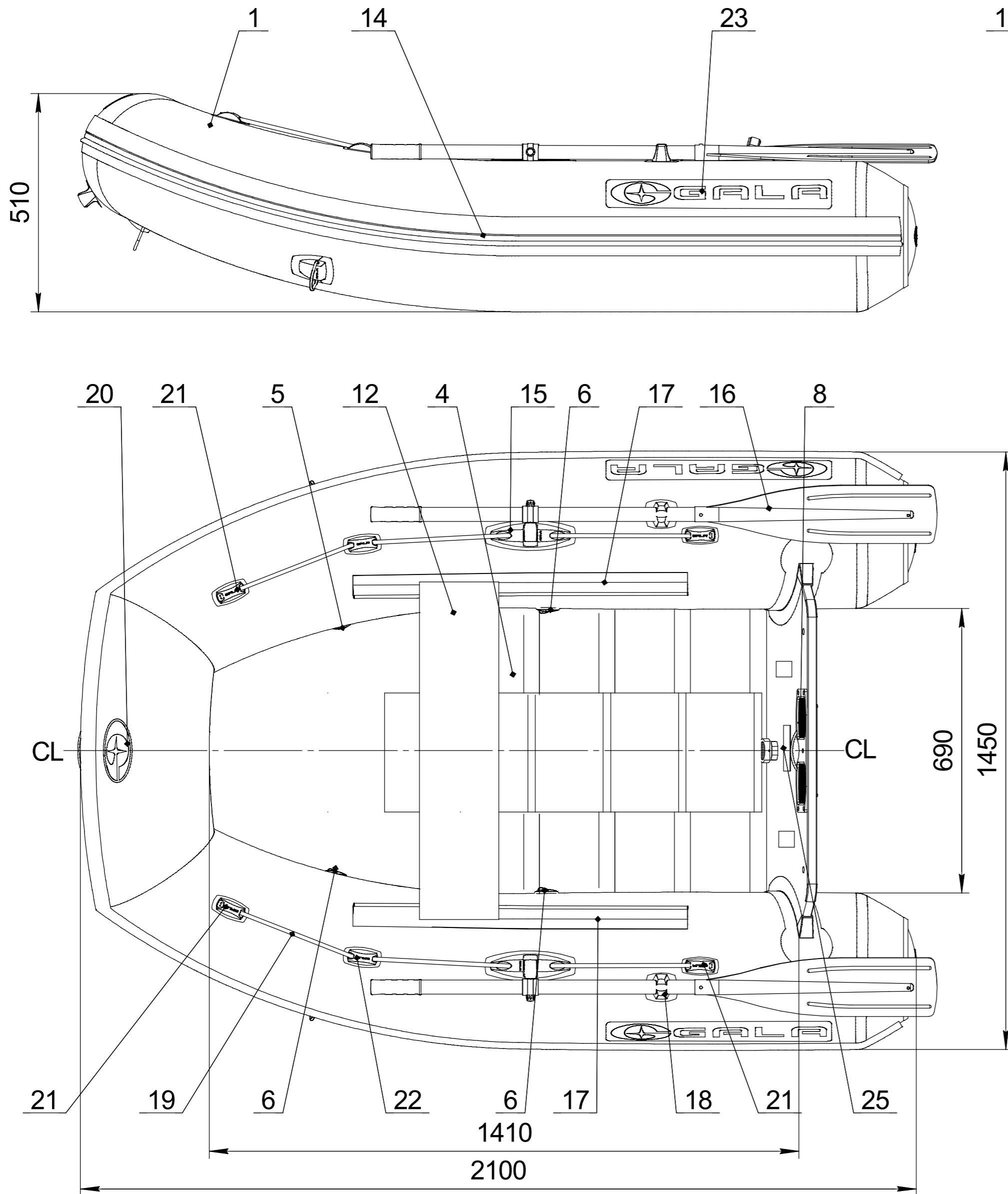

Builder's plate

GALA
INFLATABLE BOATS

Model: S210 2 +

+ + + 220 kg 484 lbs

 2.9 kW 4 HP Type: II

 25 kg 55 lbs Cat.: D

 0.2 bar 2.89 psi International Standard ISO/FDIS-6185

MADE IN UKRAINE

"CALIBR PROFI" LLC
4, Matlakhova Str., Dnipro, UKRAINE

Boat specification

Item	Item No	Description	Q-ty	Note
1		Inflatable tube for S210	1	
2		Flat bottom for S210	1	
3		Transom for S210	1	
4		Slatted deck for S210	1	
5		Over pressure valve	1	
6		Inflation-deflation valve	3	
7		Motor plate external	1	
8		Motor plate internal	1	
9		Expanding drain plug	1	
10		Tube end, PVC	2	
11		Towing eye, PVC	3	
12		Seat	1	
13		GALA handle, PVC	1	
14		Rubbing strake	1	
15		Oarlock	2	
16		Oar 140cm with rivert	2	
17		Seat holder	2	
18		Oar holder	2	
19		Lifeline	2	
20		GALA logo front	1	
21		Lifeline holder end	4	
22		Lifeline holder pass through	2	
23		GALA logo	2	
24		CIN plate	1	
25		Builder's plate	1	
26				
27				

NAME	DATE	ITEM No:		
DRAWN				
CHECKED		TITLE:		
ENG APPR.		GALA Sprinter S210		
MFG APPR.				
Q.A.				
PROPRIETARY AND CONFIDENTIAL THE INFORMATION CONTAINED IN THIS DRAWING IS THE SOLE PROPERTY OF CALIBR PROFI LLC		SIZE	DWG. NO.	REV
		SCALE: 1:10	WEIGHT:	SHEET 1 OF 1