

Inflatable boat GALA Sprinter S300D

Technical drawing

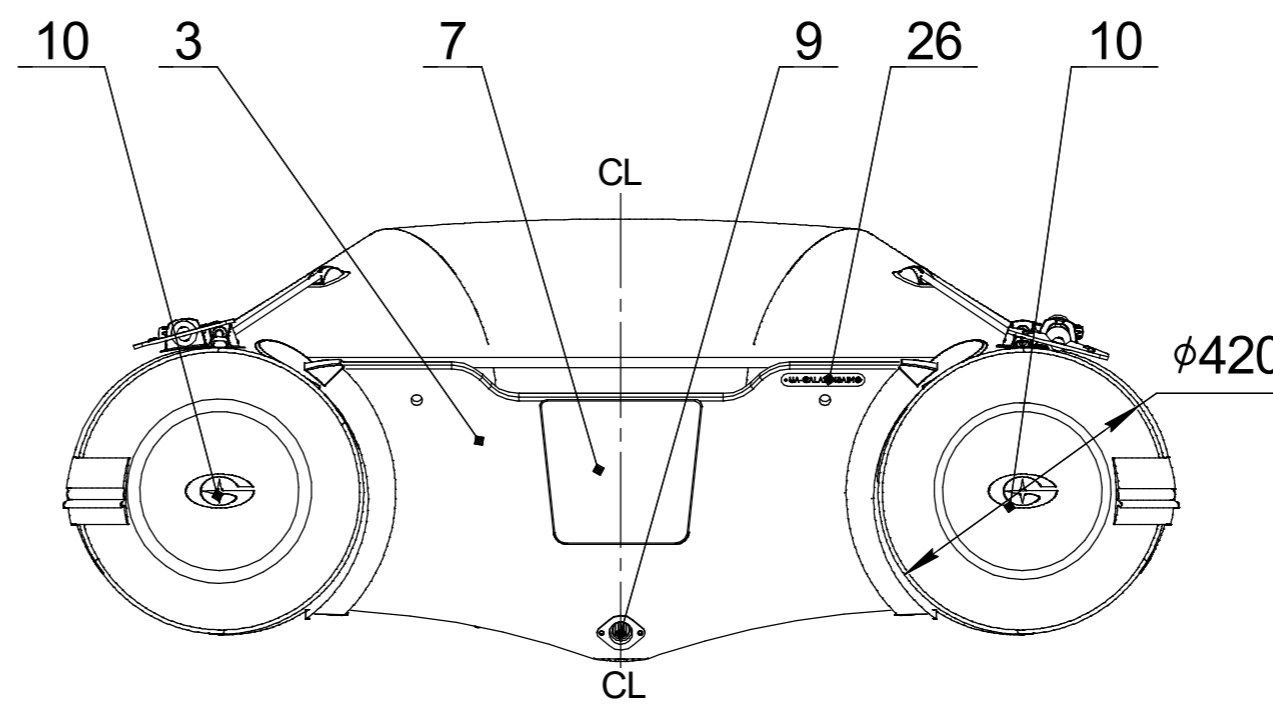
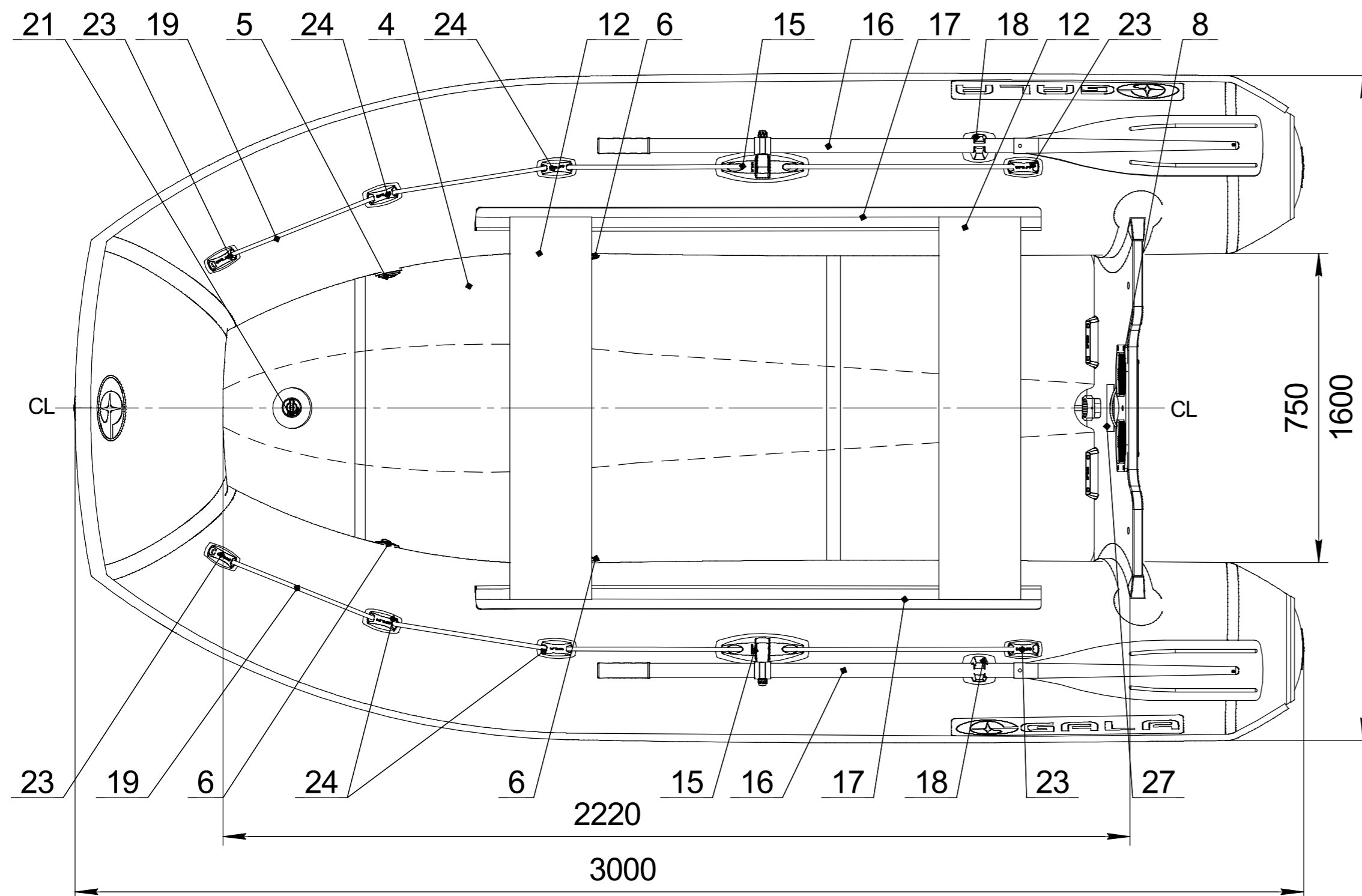
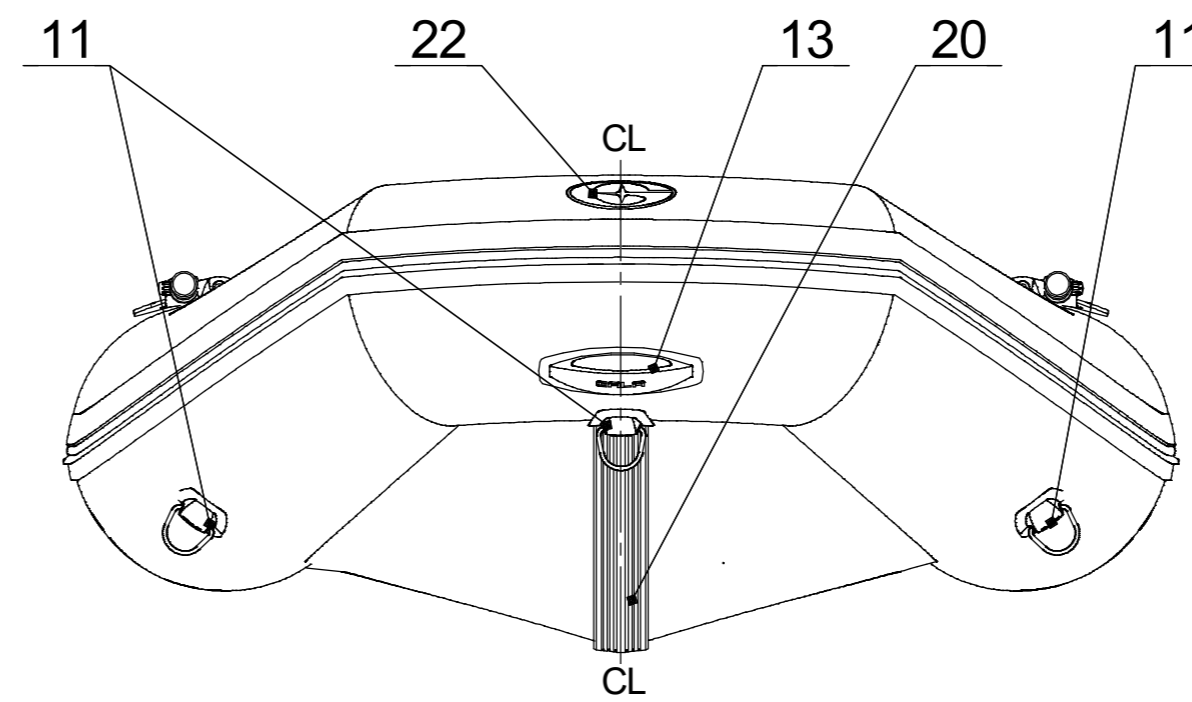
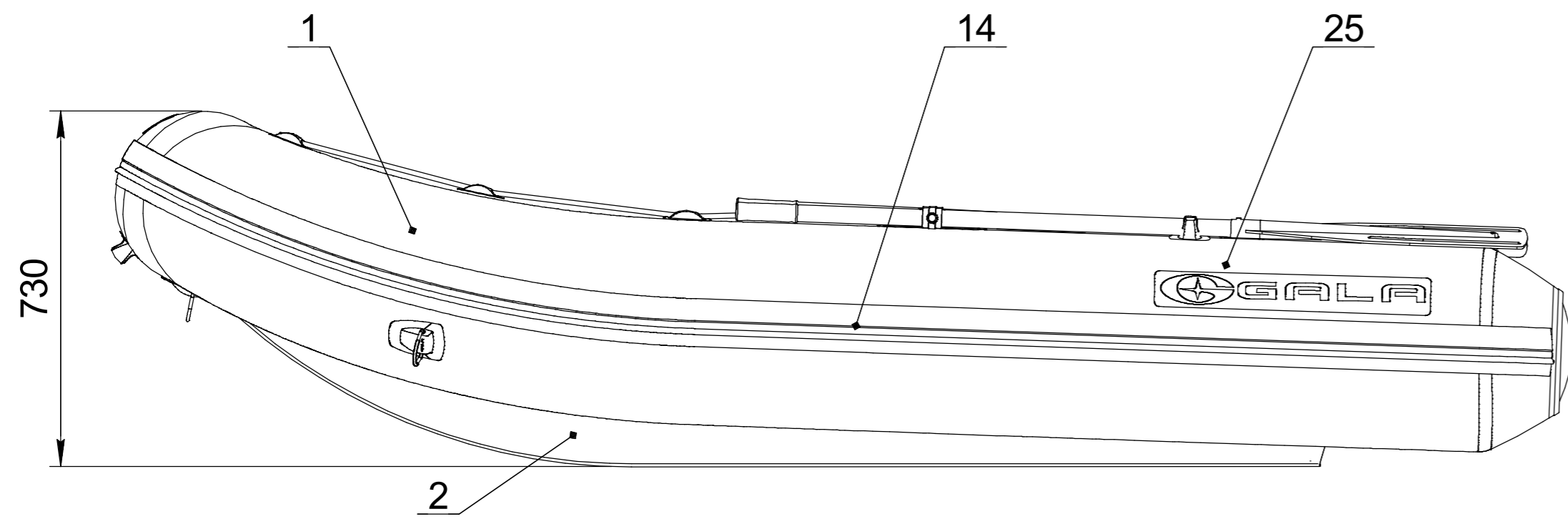

Builder's plate

GALA
INFLATABLE BOATS

Model: **S300D** 4 + 1

400 kg 880 lbs

11 kW 15 HP Type: **V**

50 kg 110 lbs Cat.: **D**

0.2 bar 2.89 psi International Standard ISO/FDIS-6185

MADE IN UKRAINE
 "CALIBR PROF" LLC
4, Matlakhova Str., Dnipro, UKRAINE

Boat specification

Item	Item No	Description	Q-ty	Note
1		Inflatable tube for S300D	1	
2		Flat bottom for S300D	1	
3		Transom for S300D	1	
4		Floorboards set for S300D	1	
5		Over pressure valve	1	
6		Inflation-deflation valve	3	
7		Motor plate external	1	
8		Motor plate internal	1	
9		Expanding drain plug	1	
10		Tube end, PVC	2	
11		Towing eye, PVC	3	
12		Seat	2	
13		GALA handle, PVC	1	
14		Rubbing strake	1	
15		Oarlock	2	
16		Oar 160cm with rivert	2	
17		Seat holder	2	
18		Oar holder	2	
19		Lifeline	2	
20		Keel protector	1	
21		Inflatable keel with inflation-deflation valve	1	
22		GALA logo front	1	
23		Lifeline holder end	4	
24		Lifeline holder pass through	4	
25		GALA logo	2	
26		CIN plate	1	
27		Builder's plate	1	

NAME	DATE	ITEM No:
DRAWN		
CHECKED		TITLE:
ENG APPR.		GALA Sprinter S300D
MFG APPR.		
Q.A.		
<small>PROPRIETARY AND CONFIDENTIAL THE INFORMATION CONTAINED IN THIS DRAWING IS THE SOLE PROPERTY OF CALIBR PROF LLC</small>		